

Metal Spraying Method— *JTST* Historical Patent #29*

UNITED STATES PATENT OFFICE
2,423,490

Richard Erhardt, Chicago, Ill.

*Application May 20, 1944, Serial No. 536,481, Patented July 8, 1947
5 Claims. (Cl. 117-105)*

This invention relates to a method and apparatus for spraying molten metal to improve the character of the metal deposit made by such a process.

For the application of molten metal sprays several devices have been developed and used which involve the feeding of a wire of the metal to be deposited through the "gun" and bringing to a focus on the wire at a melting zone streams of fuel gas, usually acetylene and oxygen adequate to melt the metal, together with a carrier stream of air at higher pressure to form a spray of the molten metal which may be projected against the body to be coated. Such devices are capable of melting and spraying steel, copper, bronzes, brasses, aluminum, zinc, lead, tin, cadmium, and other metals.

One of such devices is disclosed in U. S. Patent 1,776,632, and is currently sold under the name of the Metal Spray Company of Los Angeles.

In this device the metal wire is fed from the back of the gun but through the nozzle and at a point or zone slightly beyond the end of the nozzle the melting of the wire takes place from the heat supplied by the combustion of the acetylene and oxygen. The acetylene is usually supplied to the gun at a pressure of about 15 lbs. for the above mentioned metals with the exception of lead and tin, while for these two metals a pressure of 11 lbs. is usually adequate. The oxygen is usually supplied to the gun at a pressure of about 12 lbs. for the lead and tin and at about 17 lbs. for the other metals. The carrier stream of air fed through the gun and more or less mixed with the oxygen or acetylene within the gun is usually supplied at about 50 to 60 lbs. pressure.

I have discovered that by applying to the molten metal spray beginning at a point slightly beyond the melting zone an enclosing sheath of hydrogen supplied at relatively low pressure, for example, 1 to 5 lbs., a substantial reduction in oxidation of the metal while it is in molten condition is accomplished, and the character of the grain of the deposited metal is greatly improved.

Accordingly, one of the objects of this invention is to supply such a sheath of hydrogen in the manner described to a molten metal spray being formed and projected in the manner above described.

Another object of the invention is to provide an apparatus by means of which such a sheath of hydrogen may be applied without disturbing the normal lightning and operation of the metal

spray gun, while improving the metal depositing results obtained thereby.

Further particular objects and advantages of the invention will become apparent from a perusal of this specification.

Referring now to the drawing,

Fig. 1 is a perspective view showing, for illustrative purposes, a type of metal spraying "gun" utilized in performing my invention.

Fig. 2 is a detail view, partly in section, showing one form of the attachment which I add to such a gun for carrying out my invention.

Fig. 3 is a front elevation of the parts shown in Fig. 2.

Fig. 4 is a detail view partly in section of a modified form of the attachment for supplying hydrogen.

Fig. 5 is a front elevation of the parts shown in Fig. 4.

Referring further to the drawing, the improvement herein described may be added to any metal spraying gun, of which there are several currently on the market, and which include some means, usually an air driven turbine motivated mechanism for continuously feeding the wire from the back of the gun out through its nozzle, ducts including regulating valves for supplying a gas such as acetylene and another gas such as oxygen to the interior of the gun, so that they may be projected out through the nozzle surrounding the wire with the purpose of having the combustion take place in the atmosphere just beyond the nozzle where the wire will be melted. Such devices include provisions for supplying air at higher pressure to the interior of the gun and ejecting it along with the fuel gases to form a carrier stream for the molten metal capable of projecting it in "atomized" form against the body to be coated. The details of construction of such guns do not constitute part of this invention, as they are already well-known in this art.

As indicated above, my invention comprises adding to such guns means for applying an enclosing sheath of hydrogen gas to the atomized metal spray just slightly beyond the melting zone, and in furtherance of that object I provide, as shown in Figs. 2 and 3, an attachment for the gun comprising a manifold 1 having an annular channel 2 into which hydrogen is fed by means of the pipe 3. The manifold may be secured in any suitable manner to the gun 4. For example, the exterior of the nozzle 5 may be provided with threads, as shown at 6, and by means of corresponding threads on the manifold the latter may be secured in position. In the form of construction shown, an annular plate 7 may be utilized to seal off one side of the manifold channel, as shown in Fig. 2, and a gasket 8 may be supplied additionally for effecting this seal, the gasket being pressed against the face 9 of the housing of the gun. At separated apart intervals, surrounding the

*This series of historical patents concerned with thermal spray technology has been compiled by C.C. Berndt (SUNY at Stony Brook, NY) and K.A. Kowalsky (Flame-Spray Industries, Inc., NY).

July 8, 1947.

R. ERHARDT
METAL SPRAYING METHOD
Filed May 20, 1944

2,423,490

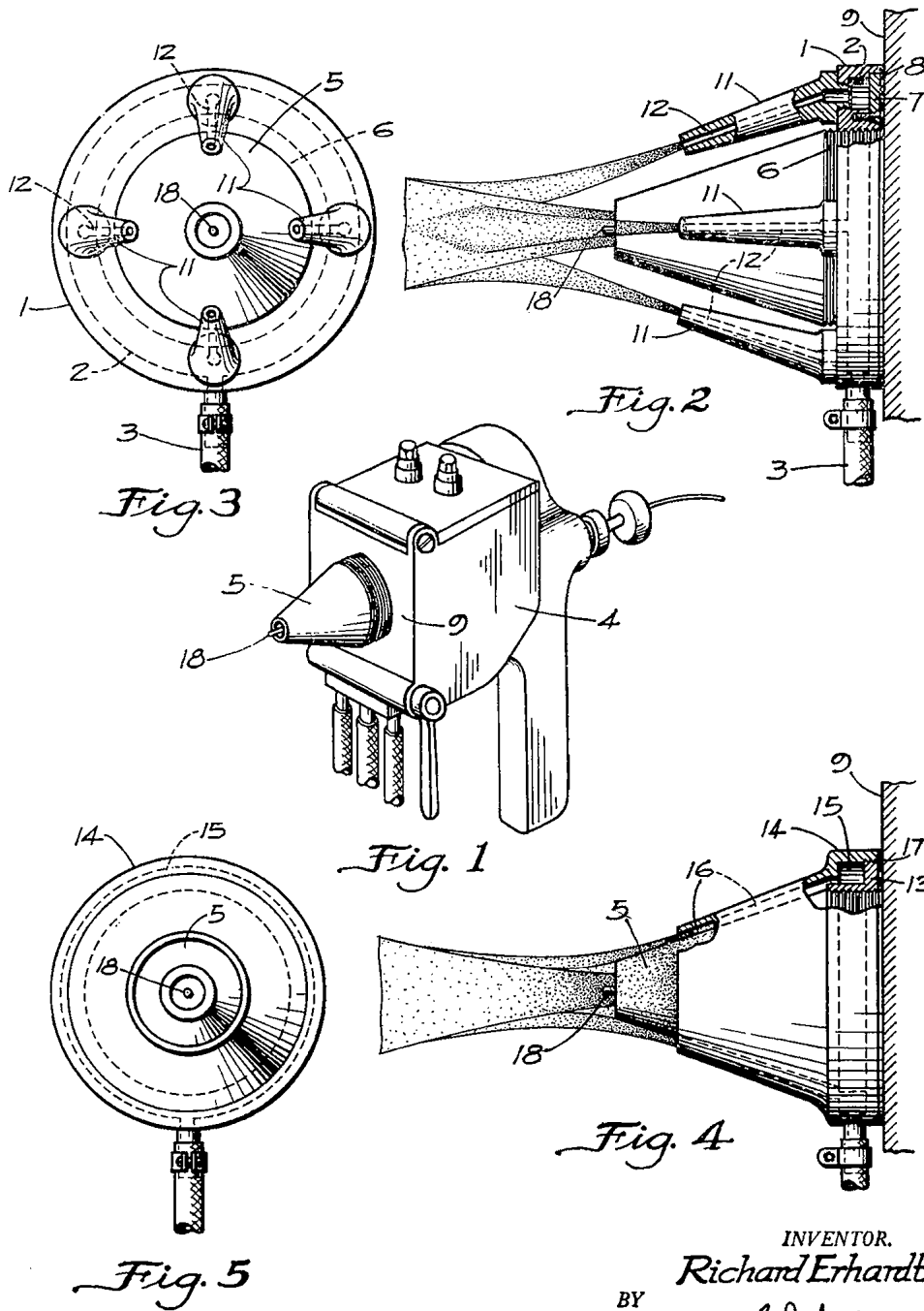

INVENTOR.
Richard Erhardt
BY
Frank J. Foley
ATTORNEY

nozzle a number of jets such as 11, each having a duct 12 may be secured in any suitable manner, for example, as shown, to the manifold for conducting the hydrogen gas forwardly toward the end of the nozzle. I have found that four jets are adequate for the

usual gun, although a greater or lesser number may be used, if desired. The control valves for regulating the fuel gases, the air and the hydrogen are not shown, as they do not constitute a part of the invention.

In the operation of the gun with the improvement shown in Figs. 2 and 3 attached thereto, after the gun has been ignited, that is by igniting the acetylene and oxygen, the air stream will be admitted to the gun and as the wire is fed forwardly, usually automatically, the metal wire will melt just beyond the end of the nozzle and the molten metal will be carried in spray form by the air stream. The hydrogen may then be turned on, and as it flows, under low pressure, that is, about 1 to 5 lbs. pressure, it will envelop the stream of air, molten metal, and products of combustion, and will be ignited by its contact with the metal spray. The oxygen required to support the combustion of the hydrogen may be derived either from the oxygen found within the metal spray or from the atmosphere through which the metal spray flows.

I have found that when the invention is used in the manner described, the deposited metal will have a character and color considerably different from that which would be deposited without the use of the hydrogen. It will, in the case of any of the above mentioned metals, have a color more closely approximating the color of the same metal produced either by casting or forging processes. Also, the grain or texture of the deposited metal will in all cases be finer, more dense, and, in the case of the hard metals, will be harder than can be obtained without the use of the hydrogen supply. Also, the bonding of the metal coating upon the article being coated is, I find, more firm and more permanent.

One of the advantages noted in metal coatings deposited in accordance with this invention resides in the fact that the deposited layers of metal are suited better for machining or grinding operations.

A modified form of the improved attachment is shown in Figs. 4 and 5. In this case the distributor for the hydrogen provides a circular orifice rather than a plurality of jets. To accomplish this, a member 13 is attached to the nozzle of the gun, for example, by the threads shown, and a shield 14 is secured thereto, for example, by the threads shown, thus providing a manifold channel 15 and a hydrogen supply passage 16 which extends around the nozzle 5 as shown. The hydrogen emitted from the circular orifice will then flow along the outside surface of the nozzle and form an enclosing sheath wholly surrounding the atomized metal spray, being ignited and burned in the same manner as was described above in connection with Fig. 2. A gasket 17 may be employed, as shown, to aid the sealing of the manifold channel 15.

In the operation of either device, as the wire 18 emerges beyond the end of the nozzle, it is subjected to the heat supplied in that zone by the combustion of the oxygen and the acetylene. This region, where the wire passes from solid to molten state, is referred to as the melting zone. As the metal melts, it is blown off the end of the wire in finely divided particles by the action of the carrier stream of air, which is usually supplied to the gun at about 60 lbs. pressure. Lower pressures such as 11 to 17 lbs. are usually adequate for the fuel gases.

One effect which appears to take place, in accordance with this invention, is that the hydrogen becomes ignited and burns beyond the melting zone, and apparently excludes the oxygen in the surrounding atmosphere from making contact with the molten metal, particularly while it is at its highest temperatures, and apparently diminishes the amount of oxygen in the carrier stream.

The reduction in oxidation of the metal spray resulting from lessened contact of the molten metal with oxygen appears to contribute to the fineness, density and improved machining characteristics of the deposited metal layer.

The addition of the hydrogen as an enclosing sheath to be burned appears to function best when it is supplied at low pressure, preferably in the range indicated. Even less than 1 lb. may be used, but it does not appear advantageous to use pressures much in excess of 5 lbs. At these low pressures the rate of flame propagation back toward the hydrogen orifice or orifices is fast enough so that the hydrogen is already burning when it strikes the conical spray of "atomized" metal.

For the purpose of illustrating convenient modes of utilizing this invention I have shown in some detail attachments for supplying the hydrogen, but it will be recognized that these attachments may be varied and otherwise constructed, without departing from the principles of the invention herein described.

Having shown and described my invention, I claim:

1. The method of spraying molten metal, which comprises feeding the metal to be melted to a melting zone, supplying oxygen and a hydrocarbon gas at moderate pressures to the melting zone for melting the material, supplying a carrier stream of air to the melting zone at a pressure and velocity exceeding those of the fuel gases, and circumferentially blanketing the projected spray stream beyond the melting zone with a sheath of hydrogen added thereto at low pressure and velocity in a direction substantially parallel to the flowing spray stream in the open atmosphere beyond the confines of the apparatus employed in protecting the spray stream.
2. The method of spraying molten metal, which comprises feeding the metal to be melted to a melting zone supplying oxygen and a hydrocarbon gas to the melting zone for melting the material, supplying a carrier stream of air for mixing with the molten metal and combustible gases, and circumferentially enclosing the projected spray of metal and gases with a sheath of hydrogen applied to said spray in a direction substantially parallel to the flowing spray stream in the open atmosphere beyond the confines of the apparatus employed in projecting the spray stream at a pressure and velocity less than half those of the fuel gases.
3. The method of spraying molten metal comprising continuously feeding the metal to a melting zone, supplying a hydrocarbons gas and oxygen to the melting zone for melting the metal, supplying to the melting zone a carrier stream of air at pressures and velocities greatly exceeding those of the fuel gases for projecting a spray of melted metal, and applying a circumferential sheath contacting the metal spray consisting of hydrogen gas supplied in a direction substantially parallel to the flowing spray stream circumferentially to the spray in the open atmosphere beyond the confines of the apparatus employed in projecting the spray stream at a pressure and velocity much lower than those of the fuel gases and beginning at a zone beyond the melting zone.
4. The method of spraying molten metal comprising continuously feeding a metal wire to a melting zone, supply-

ing acetylene and oxygen to the melting zone at pressures ranging between 10 and 17 lbs. for melting the wire, supplying air at about 60 lbs. pressure to the melting zone to atomize and project the melted metal, and enclosing the projected spray of metal and gases beginning at a point beyond the melting zone in the open atmosphere beyond the confines of the apparatus employed in projecting the spray stream with a sheath of hydrogen gas added thereto at pressures under 5 lbs. in a direction substantially parallel to the flowing spray stream.

5. The method of spraying molten metal which comprises feeding a metal wire to a melting zone, mixing oxygen and acetylene at a medium pressure and projecting them out into the atmosphere and burning them at said melting zone where the wire is thus melted, projecting along with the oxygen and acetylene a stream of air at much higher pressure to atomize the molten metal and project it onto the object being coated, and supplying to the outside of the metal spray a circumferentially enclosing sheath of hydrogen applied thereto in a direction substantially parallel to the flowing spray stream beyond said melting zone at a pressure much lower than said medium

pressure without previous mixture with the oxygen and acetylene.

RICHARD ERHARDT

References

The following references are of record in the file of this patent:

United States Patents

Number	Name	Date
1,262,134	Stolle	Apr. 9, 1918
1,617,166	Schoop	Feb. 8, 1927
1,843,842	Schoop	Feb. 2, 1932
1,776,632	Lensch, et al.	Sept. 23, 1930
1,930,373	Stubenrauch	Oct. 10, 1933
2,231,247	Bleakley	Feb. 11, 1941
2,092,150	Bleakley	Sept. 7, 1937
2,317,173	Bleakley	Apr. 20, 1943

Foreign Patents

Number	Country	Date
548,630	Great Britain	Oct. 19, 1942